

ROUGH TERRAIN CRANE

GR-120NL
GR-120N

(Standard Jib)

JAPANESE SPECIFICATIONS

CARRIER MODEL	OUTLINE	SPEC. NO.
GR-120NL	Max. total rated load 12ton X-type outrigger Winch without free-fall device	GR-120N-1-00101
GR-120NL	Max. total rated load 12ton X-type outrigger Winch with free-fall device	GR-120N-1-00102
GR-120NL	Max. total rated load 12ton H-type outrigger Winch without free-fall device	GR-120N-1-00103
GR-120NL	Max. total rated load 12ton H-type outrigger Winch with free-fall device	GR-120N-1-00104
GR-120N	Max. total rated load 4.9ton X-type outrigger Winch without free-fall device	GR-120N-1-00105
GR-120N	Max. total rated load 4.9ton X-type outrigger Winch with free-fall device	GR-120N-1-00106
GR-120N	Max. total rated load 4.9ton H-type outrigger Winch without free-fall device	GR-120N-1-00107
GR-120N	Max. total rated load 4.9ton H-type outrigger Winch with free-fall device	GR-120N-1-00108

GR

Control No. JA-03

GR-120NL, GR-120N

CRANE SPECIFICATIONS

CRANE CAPACITY

5.3m Boom	12,000kg	at 2.0m	(8part-line)	…GR-120NL
	4,900kg	at 4.0m	(4part-line)	…GR-120N
9.0m Boom	6,000kg	at 4.0m	(4part-line)	…GR-120NL
	4,900kg	at 4.5m	(4part-line)	…GR-120N
12.7m Boom	6,000kg	at 4.0m	(4part-line)	…GR-120NL
	4,900kg	at 4.5m	(4part-line)	…GR-120N
16.4m Boom	5,000kg	at 4.5m	(4part-line)	…GR-120NL
	4,900kg	at 4.5m	(4part-line)	…GR-120N
20.1m Boom	4,500kg	at 4.0m	(4part-line)	
23.8m Boom	3,000kg	at 5.5m	(4part-line)	
3.6m Jib	1,500kg	at 75°	(1part-line)	
5.5m Jib	850kg	at 70°	(1part-line)	
Single top	1,800kg		(1part-line)	

MAX.LIFTING HEIGHT

Boom	24.5m
Single top	30.0m

MAX.WORKING RADIUS

Boom	22.3m
Single top	23.2m

BOOM LENGTH

5.3m – 23.8m

BOOM EXTENSION

18.5m

BOOM EXTENSION SPEED

18.5m/52s

JIB LENGTH

3.6m, 5.5m

MAIN WINCH SINGLE LINE WINDING SPEED

124m/min (5th layer)

MAIN WINCH HOOK SPEED

31.0m/min (4 part-line)

MAIN WINCH SINGLE LINE UNWINDING SPEED

<Reference>

Standard 110m/min (5th layer)
 High speed 185m/min (5th layer) --- only on cranes
 fitted with winches without free-fall device

AUXILIARY WINCH SINGLE LINE WINDING SPEED

105m/min (3th layer)

AUXILIARY WINCH HOOK SPEED

105m/min (1 part-line)

AUXILIARY WINCH SINGLE LINE UNWINDING SPEED

<Reference>

Standard 100m/min (3rd layer)
 High speed 160m/min (3rd layer) --- only on cranes
 fitted with winches without free-fall device

BOOM ELEVATION ANGLE

-3° – 82°

BOOM ELEVATION SPEED

-3° – 82°/29s

SWING ANGLE

360° continue

SWING SPEED

2.4min⁻¹{rpm}

WIRE ROPE

Main Winch: 11.2mm x 132m (Diameter x Length)
 Spin-resistant wire rope
 Auxiliary Winch: 11.2mm x 65m (Diameter x Length)
 Spin-resistant wire rope

BOOM

6-section hydraulically telescoping boom of box
 construction
 (stages 2,3: synchronized; stages 4,5,6: synchronized)

BOOM EXTENSION

2 double-acting hydraulic cylinders
 2 wire rope type telescoping devices

JIB

2 stage which swings from and stores under the boom
 Triple offset (5°, 25°, 45°) type

SINGLE TOP

Mounted and fixed on the top boom section.

HOIST

Driven by hydraulic motor and via bevel gear reducer.
 Automatic brake
 High-speed unwind function - only on cranes fitted with
 winches without free-fall device
 Free-fall device (with foot brake) - only on cranes fitted
 with winches with free-fall device
 2 single winches
 With flow regulator valve with pressure compensation

BOOM ELEVATION

1 double-acting hydraulic cylinder
 With flow regulator valve with pressure compensation

SWING

Hydraulic motor driven planetary gear reducer
 Swing bearing
 Negative brake

OUTRIGGERS

Fully hydraulic X-type (floats mounted integrally)
 Slides and jacks each provided with independent
 operation device.
 Fully extended width 4.7m
 Middle extended width 4.3m, 3.5m, 2.5m
 Minimum extended width 1.7m (X-type), 1.64m (H-type)

OPERATION METHOD

Hydraulic pilot valve operation

MAX. VERTICAL LOAD CAPACITY OF OUTRIGGER

12.9t …GR-120NL
 10.3t …GR-120N

POWER TAKE-OFF

PTO wet multi-plate clutch

HYDRAULIC PUMPS

2 variable piston pumps
 2 gear pumps

HYDRAULIC OIL TANK CAPACITY

172 liters

SAFETY DEVICES

Automatic moment limiter (AML)
 Swing automatic stop device
 Elevation slow down and stop device
 Over-winding cutout device
 Working area control device
 Free-fall interlock device (only on cranes fitted with
 winches with free-fall device)
 Outrigger extension width detector
 Level gauge
 Hook safety latch
 Hydraulic safety valve
 Telescopic counterbalance valve
 Elevation counterbalance valve
 Jack pilot check valve
 Hydraulic oil temperature indication lamp

EQUIPMENT

Air-conditioner with dehumidifier
 Radio
 Oil cooler
 Operation pedals
 ISO arrangement: for telescoping/auxiliary hoisting
 TADANO arrangement: for elevating/telescoping

CARRIER SPECIFICATIONS

ENGINE

Model MITSUBISHI 4M50-TLE2A (with turbo charger and air cooler)
 Type 4-cycle, 4-cylinder, direct-injection, water-cooled diesel engine
 Piston displacement 4,899cc
 Max. output 125kW (170PS) at 2,800min⁻¹(rpm)
 Max. torque 451N·m (46.0kgf·m) at 1,800min⁻¹(rpm)

TORQUE CONVERTER

3-element, 1-stage unit (with automatic lock-up mechanism)

TRANSMISSION

Automatic and manual transmission
 Power shift type (wet multi-plate clutch)
 3 forward and 1 reverse speeds (with Hi/Low settings)

REDUCER

Single reduction type hypoid gear

DRIVE

2-wheel drive (4X2) / 4-wheel drive (4X4) selection

FRONT AXLE

Full floating type

REAR AXLE

Full floating type

SUSPENSION

Front Parallel leaf spring type
 Rear Parallel leaf spring type

STEERING

Fully hydraulic power steering
 With reverse steering correction mechanism

BRAKE SYSTEM

Service Brake
 Hydro-pneumatic disk brake
 Parking Brake
 Mechanically operated, internal expanding duo-servo shoe type acting on drum at transmission case rear.
 Auxiliary Brake
 Electro-pneumatic operated exhaust brake
 Auxiliary braking device for operations

FRAME

Welded box-shaped structure

ELECTRIC SYSTEM

12 V DC. 2 batteries of 24V (100Ah)

FUEL TANK CAPACITY

189 liters

TIRES

Front 275/80 R22.5 149/146J
 Rear 275/80 R22.5 149/146J

CAB

One-man type
 With interior equipment
 Rubber mounted type
 Fully adjustable foldable seat
 (with headrest, armrest and seat belt)
 Adjustable handle (tilt, telescoping)
 Intermittent type windshield/roof wiper (with washer)
 Power window
 Side visor
 Emergency steering device
 Suspension lock device

SAFETY DEVICES

Rear wheel steering lock device
 Engine over-run alarm
 Overshift prevention device
 Parking brake alarm

EQUIPMENT

Centralized oiling device

GENERAL DATA

DIMENSIONS

Overall length	7,430mm
Overall width	2,000mm
Overall height	2,800mm
Wheel base	2,750mm
Tread Front	1,680mm
Rear	1,680mm

WEIGHTS

Gross vehicle weight	(X-type)	(H-type)
Total	13,495kg	13,365kg
Front	6,960kg	6,900kg
Rear	6,535kg	6,465kg

PERFORMANCE

Max. traveling speed	49km/h
Gradeability (tan θ)	0.46
Min. turning radius	3.8m (4-wheel steering) 6.5m (2-wheel steering)

TOTAL RATED LOADS

(1) With outriggers set
[BOOM]

Unit:ton

Outriggers fully extended (4.7m)						
A B	5.3m	9.0m	12.7m	16.4m	20.1m	23.8m
1.0m	12.00(4.90)	6.00(4.90)				
1.5m	12.00(4.90)	6.00(4.90)	6.00(4.90)			
2.0m	12.00(4.90)	6.00(4.90)	6.00(4.90)	5.00(4.90)		
2.5m	10.00(4.90)	6.00(4.90)	6.00(4.90)	5.00(4.90)	4.50	
3.0m	8.20(4.90)	6.00(4.90)	6.00(4.90)	5.00(4.90)	4.50	
3.5m	7.00(4.90)	6.00(4.90)	6.00(4.90)	5.00(4.90)	4.50	3.00
4.0m	6.10(4.90)	6.00(4.90)	6.00(4.90)	5.00(4.90)	4.50	3.00
4.5m		5.20(4.90)	5.10(4.90)	5.00(4.90)	4.10	3.00
5.0m		4.65	4.60	4.50	3.80	3.00
5.5m		4.15	4.10	4.00	3.50	3.00
6.0m		3.75	3.70	3.60	3.25	2.80
7.0m		3.05	3.00	2.90	2.75	2.40
8.0m		2.70(7.7m)	2.45	2.40	2.35	2.15
9.0m			1.90	2.05	2.05	1.90
10.0m			1.55	1.70	1.75	1.65
11.0m			1.25	1.45	1.55	1.45
12.0m			1.20(11.4m)	1.25	1.35	1.30
13.0m				1.00	1.15	1.15
14.0m				0.85	1.00	1.05
15.0m				0.70	0.85	0.95
16.0m					0.70	0.80
17.0m					0.60	0.70
18.0m					0.50	0.60
19.0m					0.45(18.7m)	0.50
20.0m						0.45
22.0m						0.30
22.3m						0.27
a (°)	0 ~ 82					

A= Boom length B= Working radius

a= Boom angle range (for the unladen condition)

[BOOM]

Unit:ton

Outriggers middle extended (4.3m)						
A \ B	5.3m	9.0m	12.7m	16.4m	20.1m	23.8m
1.0m	12.00(4.90)	6.00(4.90)				
1.5m	12.00(4.90)	6.00(4.90)	6.00(4.90)			
2.0m	12.00(4.90)	6.00(4.90)	6.00(4.90)	5.00(4.90)		
2.5m	10.00(4.90)	6.00(4.90)	6.00(4.90)	5.00(4.90)	4.50	
3.0m	8.20(4.90)	6.00(4.90)	6.00(4.90)	5.00(4.90)	4.50	
3.5m	7.00(4.90)	6.00(4.90)	6.00(4.90)	5.00(4.90)	4.50	3.00
4.0m	6.10(4.90)	6.00(4.90)	6.00(4.90)	5.00(4.90)	4.50	3.00
4.5m		5.20(4.90)	5.10(4.90)	5.00(4.90)	4.10	3.00
5.0m		4.65	4.60	4.50	3.80	3.00
5.5m		4.15	4.10	4.00	3.50	3.00
6.0m		3.75	3.70	3.60	3.25	2.80
7.0m		2.90	3.00	2.90	2.75	2.40
8.0m		2.50(7.7m)	2.30	2.40	2.35	2.15
9.0m			1.80	1.90	2.05	1.90
10.0m			1.45	1.55	1.65	1.65
11.0m			1.15	1.25	1.35	1.45
12.0m			1.05(11.4m)	1.10	1.10	1.20
13.0m				0.80	0.90	1.00
14.0m				0.60	0.75	0.85
15.0m				0.50	0.60	0.75
16.0m					0.50	0.60
17.0m					0.40	0.50
18.0m					0.30	0.43
19.0m					0.25(18.7m)	0.35
20.0m						0.25
a (°)	0 ~ 82					

A= Boom length B= Working radius

a= Boom angle range (for the unladen condition)

[BOOM]

Unit:ton

Outriggers middle extended (3.5m)						
A \ B	5.3m	9.0m	12.7m	16.4m	20.1m	23.8m
1.0m	12.00(4.90)	6.00(4.90)				
1.5m	12.00(4.90)	6.00(4.90)	6.00(4.90)			
2.0m	12.00(4.90)	6.00(4.90)	6.00(4.90)	5.00(4.90)		
2.5m	10.00(4.90)	6.00(4.90)	6.00(4.90)	5.00(4.90)	4.50	
3.0m	8.20(4.90)	6.00(4.90)	6.00(4.90)	5.00(4.90)	4.50	
3.5m	7.00(4.90)	6.00(4.90)	6.00(4.90)	5.00(4.90)	4.50	3.00
4.0m	6.10(4.90)	6.00(4.90)	6.00(4.90)	5.00(4.90)	4.50	3.00
4.5m		4.75	4.70	5.00(4.90)	4.10	3.00
5.0m		3.85	3.85	4.10	3.80	3.00
5.5m		3.25	3.25	3.50	3.50	3.00
6.0m		2.75	2.75	3.00	3.15	2.80
7.0m		2.05	2.00	2.25	2.40	2.40
8.0m		1.65(7.7m)	1.50	1.70	1.85	1.90
9.0m			1.10	1.30	1.45	1.50
10.0m			0.80	1.00	1.15	1.20
11.0m			0.60	0.80	0.90	0.97
12.0m			0.40(11.4m)	0.60	0.70	0.77
13.0m				0.45	0.55	0.62
14.0m				0.30	0.40	0.50
15.0m				0.25	0.30	0.40
16.0m					0.20	0.30
17.0m						0.20
a (°)	0 ~ 82				21 ~ 82	36 ~ 82

A= Boom length B= Working radius
a= Boom angle range (for the unladen condition)

[BOOM]

Unit:ton

Outriggers middle extended (2.5m)						
A \ B	5.3m	9.0m	12.7m	16.4m	20.1m	23.8m
1.0m	12.00(4.90)	6.00(4.90)				
1.5m	12.00(4.90)	6.00(4.90)	6.00(4.90)			
2.0m	12.00(4.90)	6.00(4.90)	6.00(4.90)	5.00(4.90)		
2.5m	8.00(4.90)	6.00(4.90)	6.00(4.90)	5.00(4.90)	4.50	
3.0m	5.70(4.90)	5.50(4.90)	5.50(4.90)	5.00(4.90)	4.50	
3.5m	4.25	4.30	4.30	4.50	4.50	3.00
4.0m	3.45	3.35	3.35	3.55	3.70	3.00
4.5m		2.60	2.65	2.90	3.05	3.00
5.0m		2.10	2.15	2.35	2.55	2.60
5.5m		1.75	1.75	1.95	2.15	2.25
6.0m		1.45	1.40	1.65	1.80	1.95
7.0m		1.00	0.95	1.15	1.30	1.40
8.0m		0.70(7.7m)	0.65	0.85	0.95	1.05
9.0m			0.40	0.60	0.70	0.77
10.0m			0.20	0.40	0.50	0.60
11.0m				0.25	0.35	0.40
12.0m					0.20	0.30
13.0m						0.20
a (°)	0 ~ 82		19 ~ 82	33 ~ 82	44 ~ 82	50 ~ 82

A= Boom length B= Working radius

a= Boom angle range (for the unladen condition)

[BOOM]

Unit:ton

Outriggers minimum extended (*)						
A \ B	5.3m	9.0m	12.7m	16.4m	20.1m	23.8m
1.0m	8.00(4.90)	6.00(4.90)				
1.5m	7.00(4.90)	6.00(4.90)	6.00(4.90)			
2.0m	5.50(4.90)	5.40(4.90)	5.50(4.90)	5.00(4.90)		
2.5m	3.70	3.80	3.55	3.20	3.20	
3.0m	2.70	2.85	2.65	2.6	2.60	
3.5m	2.10	2.00	2.00	2.05	2.10	2.10
4.0m	1.60	1.55	1.55	1.60	1.70	1.75
4.5m		1.20	1.20	1.25	1.40	1.45
5.0m		0.90	0.95	1.00	1.15	1.25
5.5m		0.70	0.75	0.80	0.95	1.05
6.0m		0.55	0.55	0.65	0.80	0.90
7.0m		0.25	0.20	0.40	0.55	0.60
8.0m						0.35
a (°)	0 ~ 82	18 ~ 82	50 ~ 82	56 ~ 82	60 ~ 82	63 ~ 82

A= Boom length B= Working radius

a= Boom angle range (for the unladen condition)

* 1.7 m---X-type outrigger

1.64m---H-type outrigger

[JIB]

Unit:ton

Outriggers fully extended (4.7m)												-360°-	
C D	23.8m Boom + 3.6m Jib						23.8m Boom + 5.5m Jib						
	5° □		25° □		45° □		5° □		25° □		45° □		
E (°)	B(m)	M	B(m)	M	B(m)	M	B(m)	M	B(m)	M	B(m)	M	
82	3.8	1.50	4.7	1.20	5.9	0.90	3.9	0.85	6.2	0.70	7.2	0.60	
80	4.8	1.50	5.7	1.20	6.8	0.90	5.0	0.85	7.3	0.70	8.2	0.60	
75	7.3	1.50	8.1	1.20	9.2	0.90	7.7	0.85	9.9	0.70	10.6	0.55	
70	9.7	1.25	10.4	1.00	11.4	0.85	10.3	0.85	12.2	0.65	12.8	0.53	
65	12.0	1.05	12.5	0.90	13.4	0.77	12.6	0.80	14.3	0.60	15.0	0.50	
60	14.2	0.90	14.6	0.80	15.4	0.70	14.8	0.66	16.3	0.55	17.0	0.48	
55	16.2	0.72	16.4	0.68	17.0	0.65	16.9	0.58	18.0	0.50	18.9	0.45	
50	18.0	0.55	18.2	0.52	18.5	0.52	18.8	0.50	19.6	0.45	20.5	0.42	
45	19.7	0.40	19.8	0.38	19.8	0.38	20.5	0.37	21.1	0.34	22.0	0.34	
40	21.1	0.28	21.2	0.28			22.3	0.25	23.2	0.24			
35	22.3	0.19	22.4	0.19									
a (°)	34 ~ 82				44 ~ 82		39 ~ 82				44 ~ 82		

Unit:ton

Outriggers middle extended (4.3m)												-Over sides-	
C D	23.8m Boom + 3.6m Jib						23.8m Boom + 5.5m Jib						
	5° □		25° □		45° □		5° □		25° □		45° □		
E (°)	B(m)	M	B(m)	M	B(m)	M	B(m)	M	B(m)	M	B(m)	M	
82	3.8	1.50	4.7	1.20	5.9	0.90	3.9	0.85	6.1	0.70	7.1	0.60	
80	4.8	1.50	5.7	1.20	6.9	0.90	5.0	0.85	7.2	0.70	8.2	0.60	
75	7.3	1.50	8.1	1.20	9.2	0.90	7.7	0.85	9.9	0.70	10.6	0.55	
70	9.7	1.25	10.4	1.00	11.4	0.85	10.2	0.85	12.2	0.65	12.8	0.53	
65	12.0	1.05	12.5	0.90	13.4	0.77	12.6	0.80	14.3	0.60	15.0	0.50	
60	14.2	0.82	14.5	0.78	15.3	0.65	14.8	0.66	16.3	0.55	17.0	0.48	
55	16.1	0.56	16.4	0.56	16.9	0.53	16.8	0.52	18.0	0.45	18.8	0.40	
50	17.9	0.39	18.1	0.39	18.4	0.37	18.7	0.36	19.6	0.33	20.5	0.32	
45	19.6	0.27	19.7	0.27	19.8	0.24	20.5	0.24	21.1	0.22	21.9	0.21	
40	21.0	0.17	21.1	0.17									
a (°)	39 ~ 82				44 ~ 82		44 ~ 82						

B= Working radius C= Jib length D= Jib offset
E= Boom angle M= Total rated loads
a= Boom angle range (for the unladen condition)

[JIB]

Unit:ton

Outriggers middle extended (3.5m) –Over sides–												
C	23.8m Boom + 3.6m Jib						23.8m Boom + 5.5m Jib					
	5° □		25° □		45° □		5° □		25° □		45° □	
E (°)	B(m)	M	B(m)	M	B(m)	M	B(m)	M	B(m)	M	B(m)	M
82	3.8	1.50	4.7	1.20	5.9	0.90	3.9	0.85	6.1	0.70	7.2	0.60
80	4.8	1.50	5.7	1.20	6.8	0.90	5.0	0.85	7.3	0.70	8.2	0.60
75	7.3	1.50	8.1	1.20	9.2	0.90	7.7	0.85	9.9	0.70	10.6	0.55
70	9.6	1.10	10.3	1.00	11.4	0.85	10.2	0.85	12.2	0.65	12.8	0.53
65	11.8	0.74	12.4	0.72	13.3	0.67	12.5	0.70	14.2	0.52	14.9	0.45
60	13.9	0.48	14.4	0.46	15.2	0.43	14.6	0.42	16.2	0.37	16.9	0.35
55	15.9	0.28	16.2	0.27	16.8	0.26	16.9	0.25	17.9	0.22	18.7	0.21
a (°)	54 ~ 82						54 ~ 82					

Unit:ton

Outriggers middle extended (2.5m) –Over sides–												
C	23.8m Boom + 3.6m Jib						23.8m Boom + 5.5m Jib					
	5° □		25° □		45° □		5° □		25° □		45° □	
E (°)	B(m)	M	B(m)	M	B(m)	M	B(m)	M	B(m)	M	B(m)	M
82	3.8	1.50	4.7	1.20	5.9	0.90	3.9	0.85	6.1	0.70	7.2	0.60
75	7.2	1.10	8.0	0.90	9.1	0.80	7.7	0.85	9.8	0.65	10.5	0.50
70	9.5	0.58	10.1	0.50	11.1	0.45	10.0	0.50	12.0	0.40	12.7	0.35
65	11.6	0.25	12.1	0.22	13.1	0.20	12.2	0.20				
a (°)	64 ~ 82						64 ~ 82			69 ~ 82		

B= Working radius C= Jib length D= Jib offset
 E= Boom angle M= Total rated loads
 a= Boom angle range (for the unladen condition)

PRECAUTIONS TO BE TAKEN WHEN THE OUTRIGGERS ARE EXTENDED:

- The values in parentheses are for GR-120N.
- The total rated loads shown are for the case where the crane is set horizontally on firm level ground. They include the weights of the slings and hooks.
The values above the bold lines are based on the crane strength while those below are based on the crane stability.
- Since the total rated loads are based on the actual working radii including the deflection of the boom, operations should be performed in accordance with the working radii.
- Perform jib operations in accordance with the boom angle, irrespective of the boom length.
The working radii are reference values for the case where the jib is mounted to a 23.8m boom.
- The total rated load for the single top shall be the value obtained by subtracting the weight of the main hook from the total rated load of the boom and must not exceed 1.8t.
- High-speed unwind function (only on cranes fitted with winches without free-fall device) should be performed only when lowering the hook alone and sudden braking operations must be avoided.
- As a rule, free-fall operation (only on cranes fitted with winches with free-fall device) should be performed only when lowering the hook alone. If a hoisted load must be lowered by free-fall operation, the load must be kept below 1/5th of the total rated load and sudden braking operations must be avoided.
- The table below shows the standard number of part lines for each boom length. When using with other than this number of part lines, the load per line should not exceed 1.5t for the main winch, and 1.8t for the auxiliary winch.

A	5.3m	9.0m	12.7m	16.4m	20.1m	23.8m	Jib/Single top
H	8(4)	4	4	4	4	4	1
K	12t Hook (4.9t Hook)						1.8t Hook
L	90kg (90kg)						25kg

The values in parentheses are for GR-120N.

A= Boom length H= No. of part-lines

K= Hook type L= Hook weight

- The hoisting performance for the "Over sides" range will differ according to the extended width of the outriggers. Operations should be performed in accordance with the performance corresponding to the extended width. Also, although the hoisting performances for the "Over front" and "Over rear" ranges are equivalent to those of the "outriggers fully extended" condition, the front and rear ranges (angle α) will differ according to the width to which the outriggers are extended in the left and right directions.

Extended width	Middle extended (4.3m)	Middle extended (3.5m)	Middle extended (2.5m)	Minimum extended (*)
Angle α° □	35	25	15	5

* = 1.7m X-type outrigger 1.64m H-type outrigger

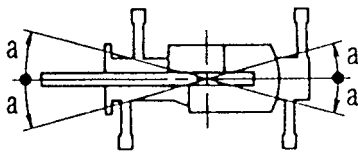

(2) Without outriggers

Unit:ton

B (m)	Stationary					
	5.3m Boom		9.0m Boom		12.7m Boom	
	K	G	K	G	K	G
1.0	3.60	2.80	3.60	2.80		
1.5	3.60	2.80	3.60	2.80	3.60	2.80
2.0	3.40	2.80	3.40	2.80	3.40	2.80
2.5	3.10	2.15	3.10	2.10	3.10	2.05
3.0	2.65	1.60	2.60	1.55	2.55	1.50
3.5	2.30	1.25	2.20	1.20	2.10	1.10
4.0	2.00	0.90	1.90	0.80	1.70	0.70
4.5			1.60	0.50	1.40	0.40
5.0			1.30		1.10	
5.5			1.10		0.95	
6.0			0.90		0.80	
7.0			0.50		0.50	
a (°)	0~82		26~82	50~82	52~82	63~82

Unit:ton

B (m)	Creep (travelling at 1.6km/h or less)					
	5.3m Boom		9.0m Boom		12.7m Boom	
	K	G	K	G	K	G
1.0	3.20	2.00	3.20	2.00		
1.5	3.20	2.00	3.20	2.00	3.20	2.00
2.0	3.00	2.00	3.00	2.00	3.00	2.00
2.5	2.80	1.55	2.75	1.50	2.65	1.45
3.0	2.40	1.10	2.30	1.05	2.20	1.00
3.5	2.00	0.85	1.90	0.75	1.80	0.65
4.0	1.70	0.60	1.65	0.50	1.50	0.40
4.5			1.40	0.30	1.25	
5.0			1.15		1.00	
5.5			0.95		0.85	
6.0			0.80		0.70	
7.0			0.45		0.45	
a (°)	0~82		26~82	50~82	52~82	66~82

B= Working radius K= Front G= 360°
a= Boom angle range (for the unladen condition)

PRECAUTIONS TO BE TAKEN WHEN THE OUTRIGGERS ARE NOT MOUNTED:

1. The total rated loads shown are for the case where the tire air pressure on firm level ground is as specified 875kPa (8.75kgf/cm²), and the crane is completely spring-locked. They include the weights of the slings and hooks (main hook: 90kg, auxiliary hook: 25kg).
The values above the bold lines are based on the crane strength while those below are based on the crane stability. The foundation, working conditions, etc. should be taken into consideration for actual work.
2. Since the total rated loads are based on the actual working radii including the deflection of the boom and the tires, operations should be performed in accordance with the working radii.
3. The table below shows the standard number of part lines for each boom length. When using with other than this number of part lines, the load per line should not exceed 1.5t for the main winch, and 1.8t for the auxiliary winch.

A	5.3m	9.0m	12.7m	Single top
H	4	4	4	1

A= Boom length H= No. of part-lines

4. If the spring lock is not available or not used, no load can be hoisted in the over-side area. "Over front" crane operations should be performed only when the AML "over-front area indicator lamp" is lit. The boom must be kept inside a 2° area over front of the carrier when performing "Over front" crane operations without the outriggers.

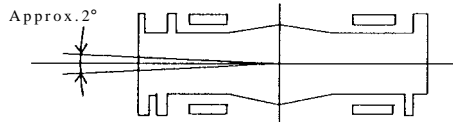

5. The total rated load for the single top shall be the value obtained by subtracting the weight of the main hook from the total rated load of the boom and must not exceed 1.8t.
6. High-speed unwind function (only on cranes fitted with winches without free-fall device) and free-fall operations (only on cranes fitted with winches with free-fall device) should not be performed without outriggers. Booms over 12.7m in length and jibs should not be used without outriggers.
7. The "Drive, Speed Selection" switch should be set to "4-wheel / Lo" for creeping while hoisting a load.
8. When creeping while hoisting a load, the swing brake should be applied, the load should be kept as close to the ground as possible but not touching the ground and the speed should be kept at 1.6km/h or less. In particular, any abrupt steering, starting or braking must be avoided.
9. Crane operations should not be performed when creeping while hoisting a load.

WORKING RADIUS - LIFTING HEIGHT

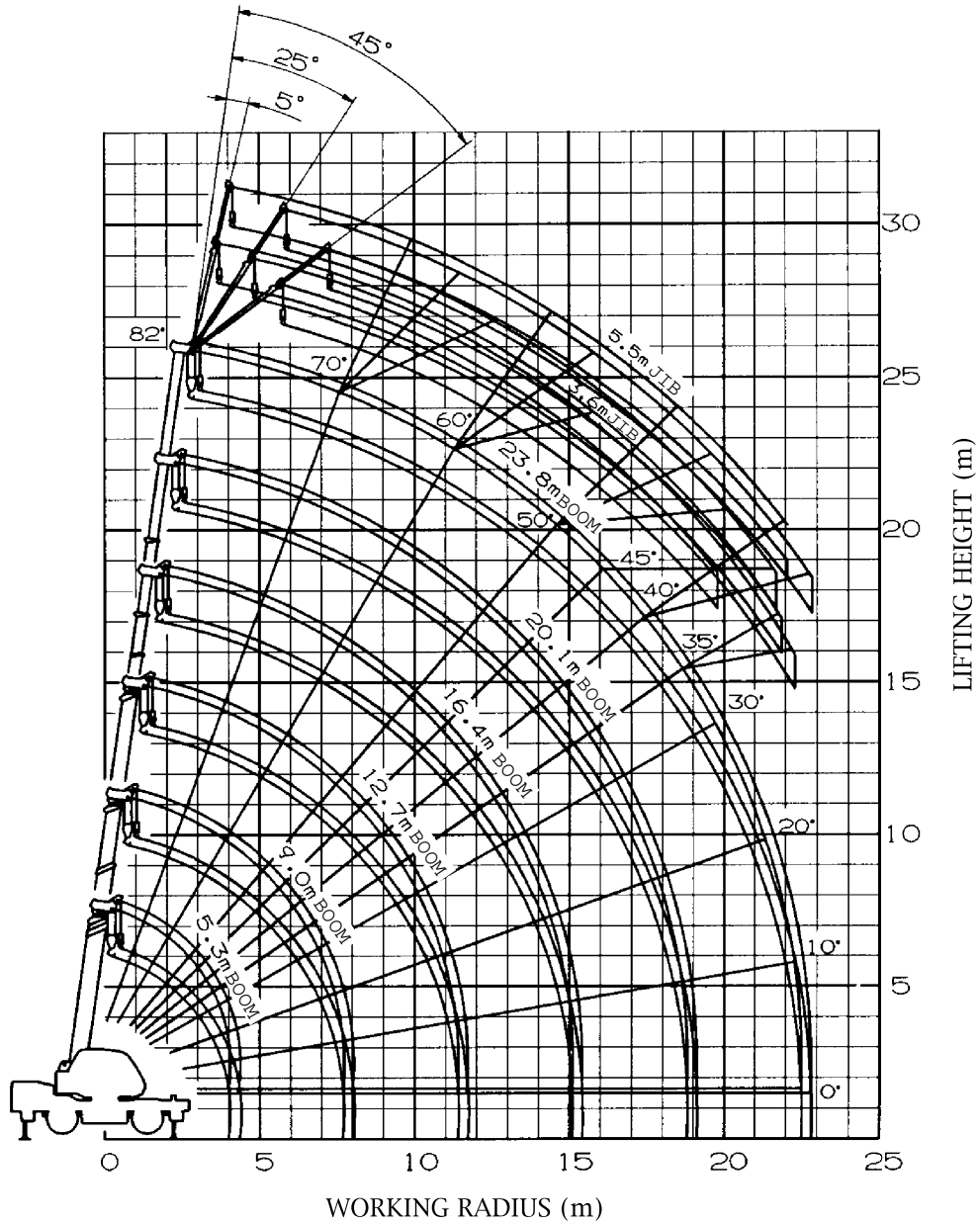

NOTES:

1. The deflection of the boom is not incorporated in the figure above.
2. The figure above is for the case where the outriggers are fully extended (360°).

DIMENSIONS (1/100)

[X-type outrigger crane]

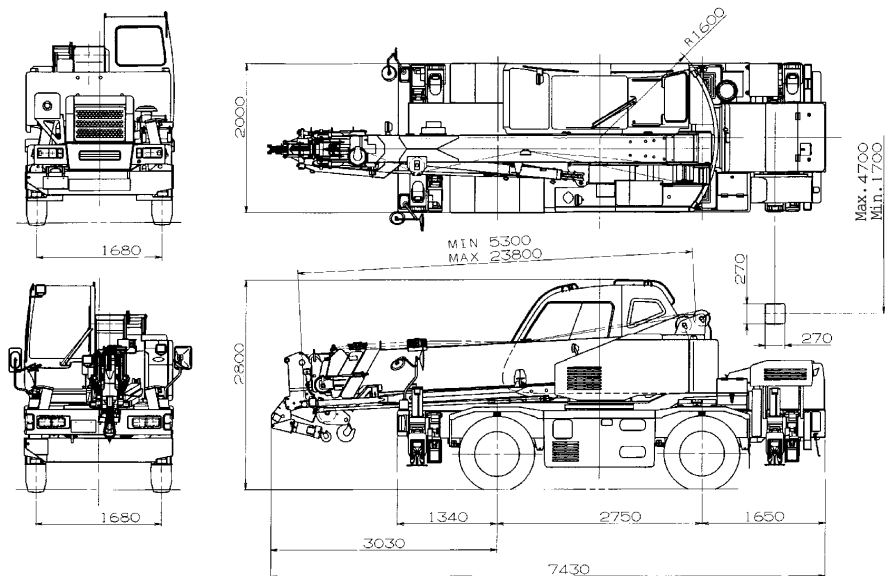

DIMENSIONS (1/100)

[H-type outrigger crane]

